



US 20050139476A1

(19) **United States**

(12) **Patent Application Publication**

**Price**

(10) **Pub. No.: US 2005/0139476 A1**

(43) **Pub. Date:**

**Jun. 30, 2005**

(54) **ANODIZING SYSTEM WITH A COATING THICKNESS MONITOR AND AN ANODIZED PRODUCT**

(52) **U.S. Cl.** ..... **205/84; 205/324**

(76) **Inventor: Joseph K. Price, Nebo, NC (US)**

(57) **ABSTRACT**

Correspondence Address:  
**SMITH MOORE LLP**  
**P.O. BOX 21927**  
**GREENSBORO, NC 27420 (US)**

(21) **Appl. No.: 10/952,700**

(22) **Filed: Sep. 29, 2004**

**Related U.S. Application Data**

(62) **Division of application No. 10/748,704, filed on Dec. 30, 2003.**

**Publication Classification**

(51) **Int. Cl.<sup>7</sup> ..... C25D 11/04; C25D 21/12**

An anodizing system for forming an anodized coating on at least a portion of a substrate thereby creating an anodized substrate is disclosed. The anodizing system includes a bath, a coating thickness monitor, at least one probe and at least one controller. The coating thickness monitor includes at least one radiation source directed at at least a portion of the anodized substrate; at least one probe for capturing at least a portion of the radiation reflected and refracted by the anodized coating on the anodized substrate, the captured radiation being at least a portion of the radiation directed the anodized substrate from the radiation source; and at least one detector in communication with the at least one probe, the at least one detector capable of processing the captured radiation to allow a determination of at least the thickness.

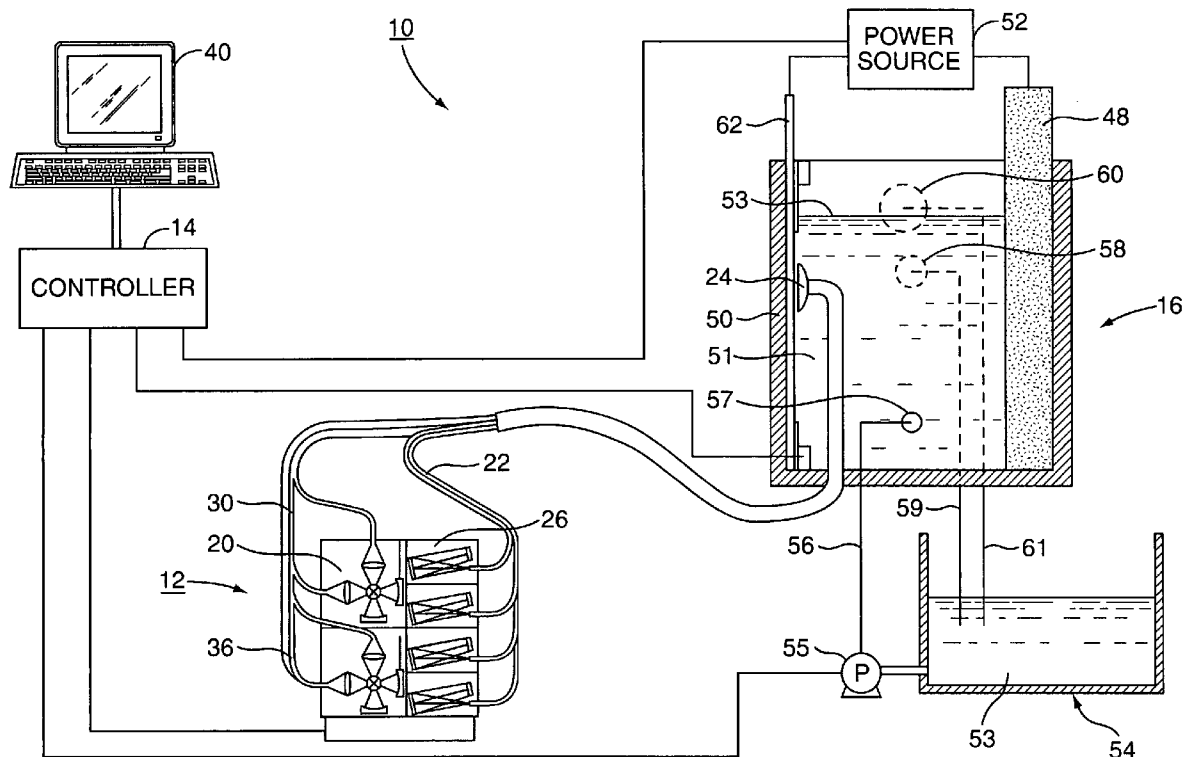

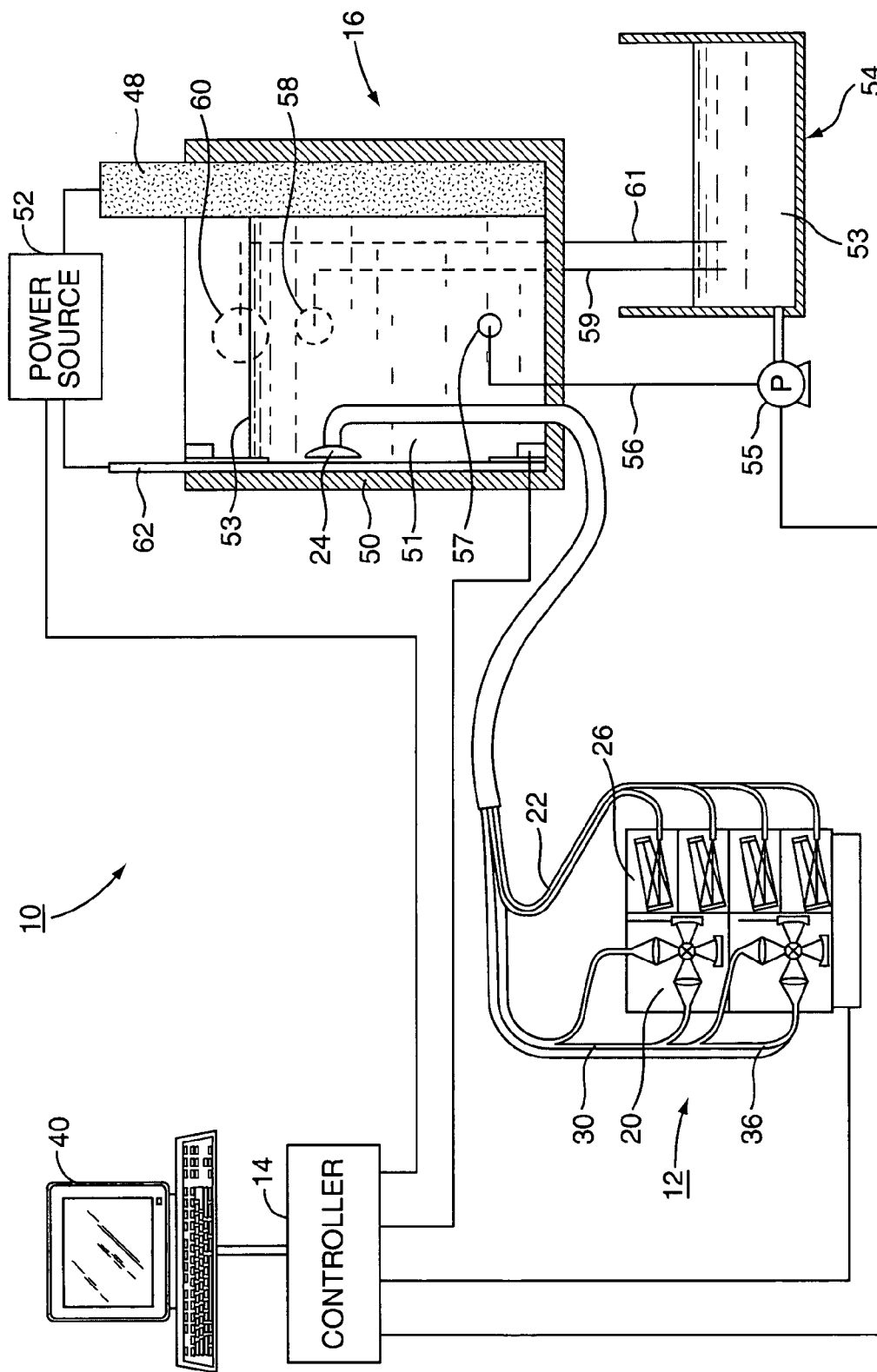

FIG. 1

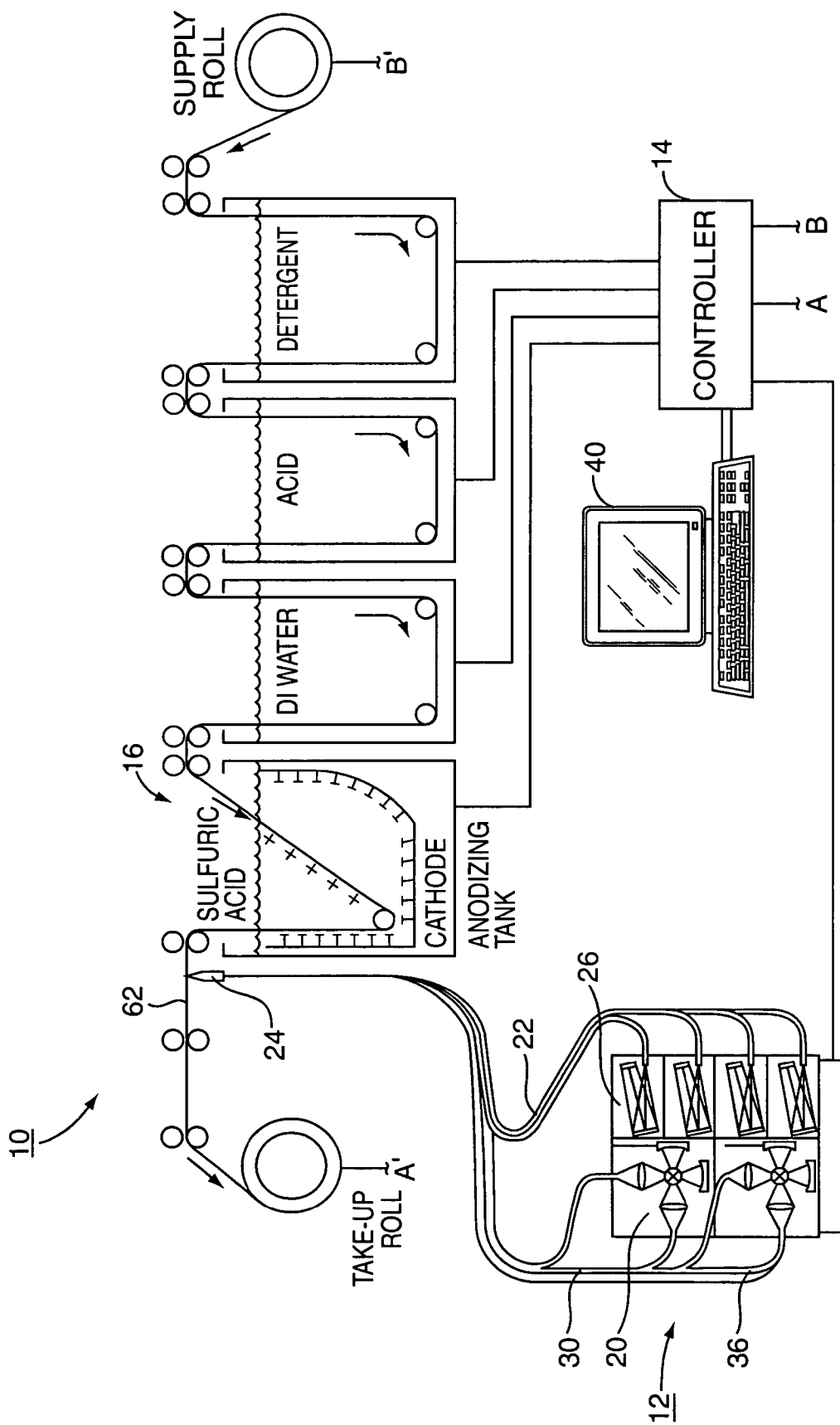

FIG. 2

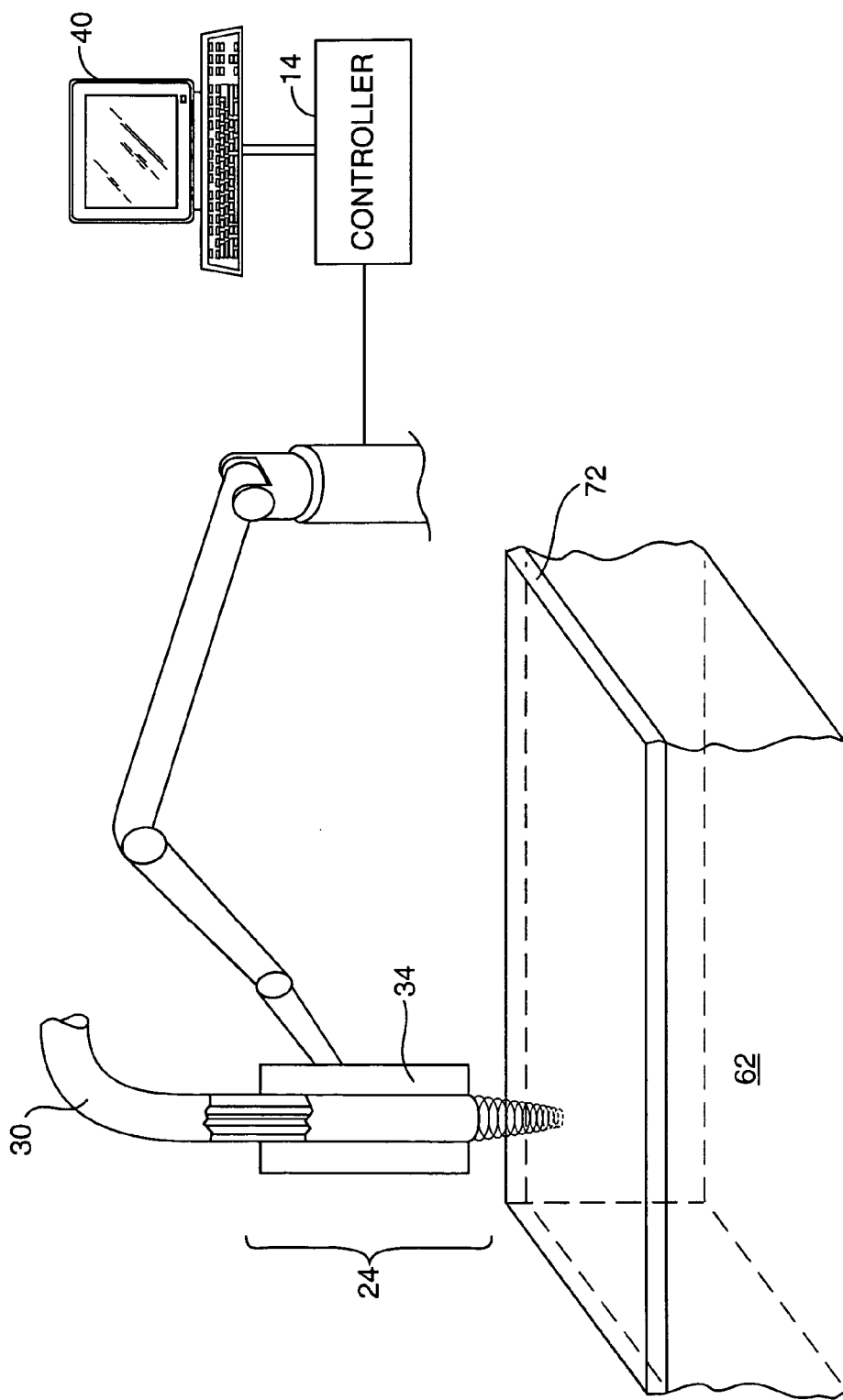

FIG. 3

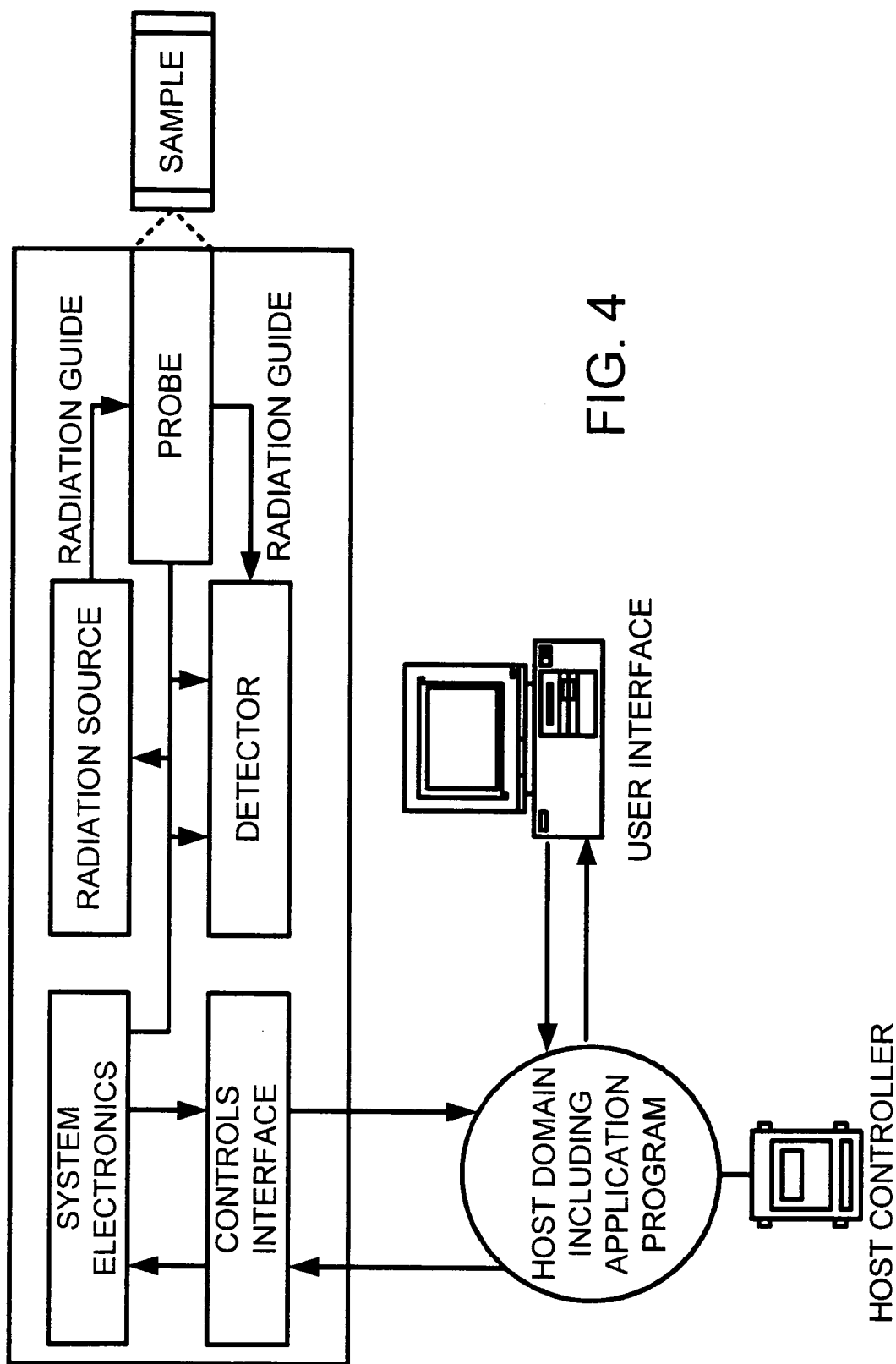

FIG. 4

FIG. 5

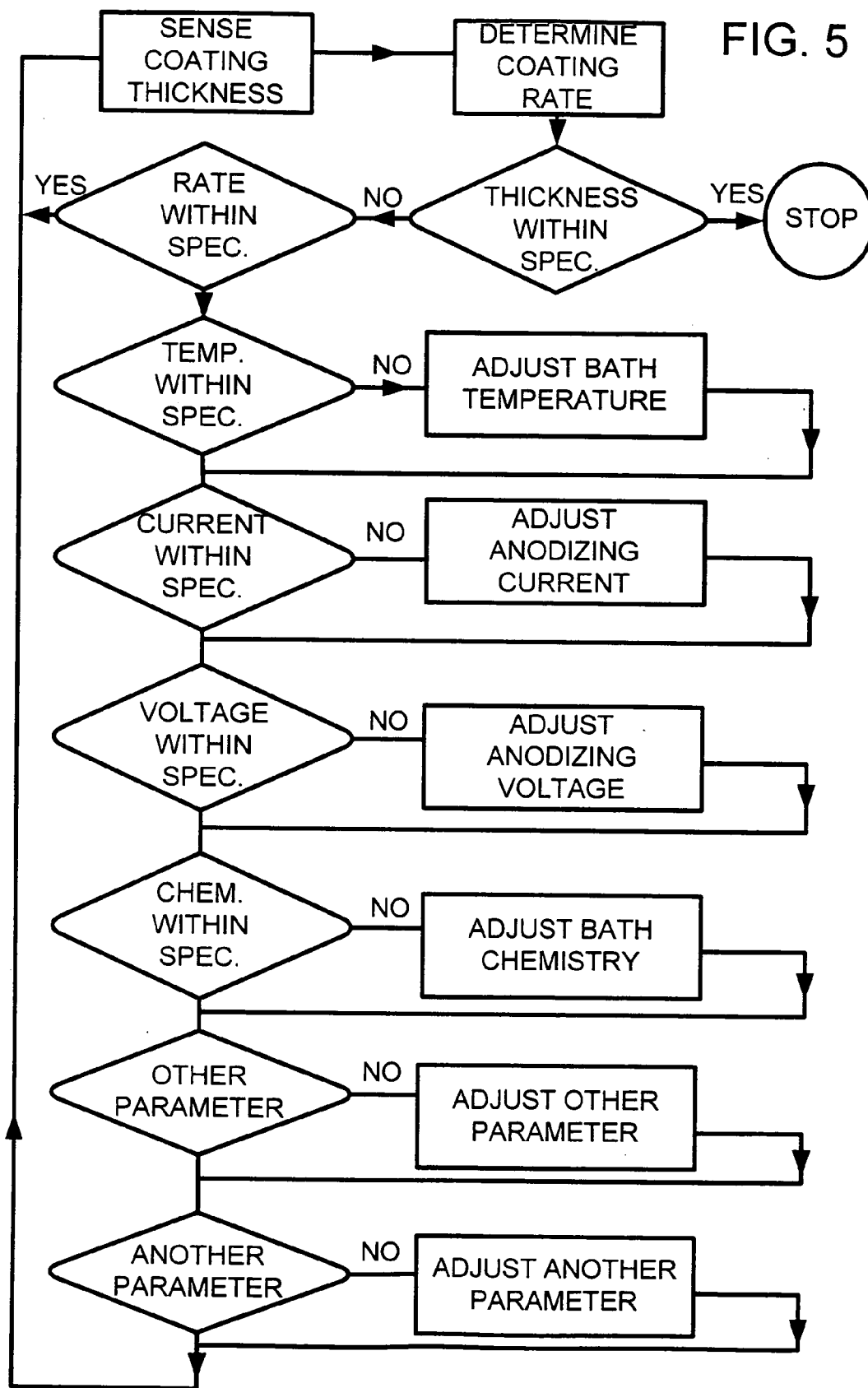
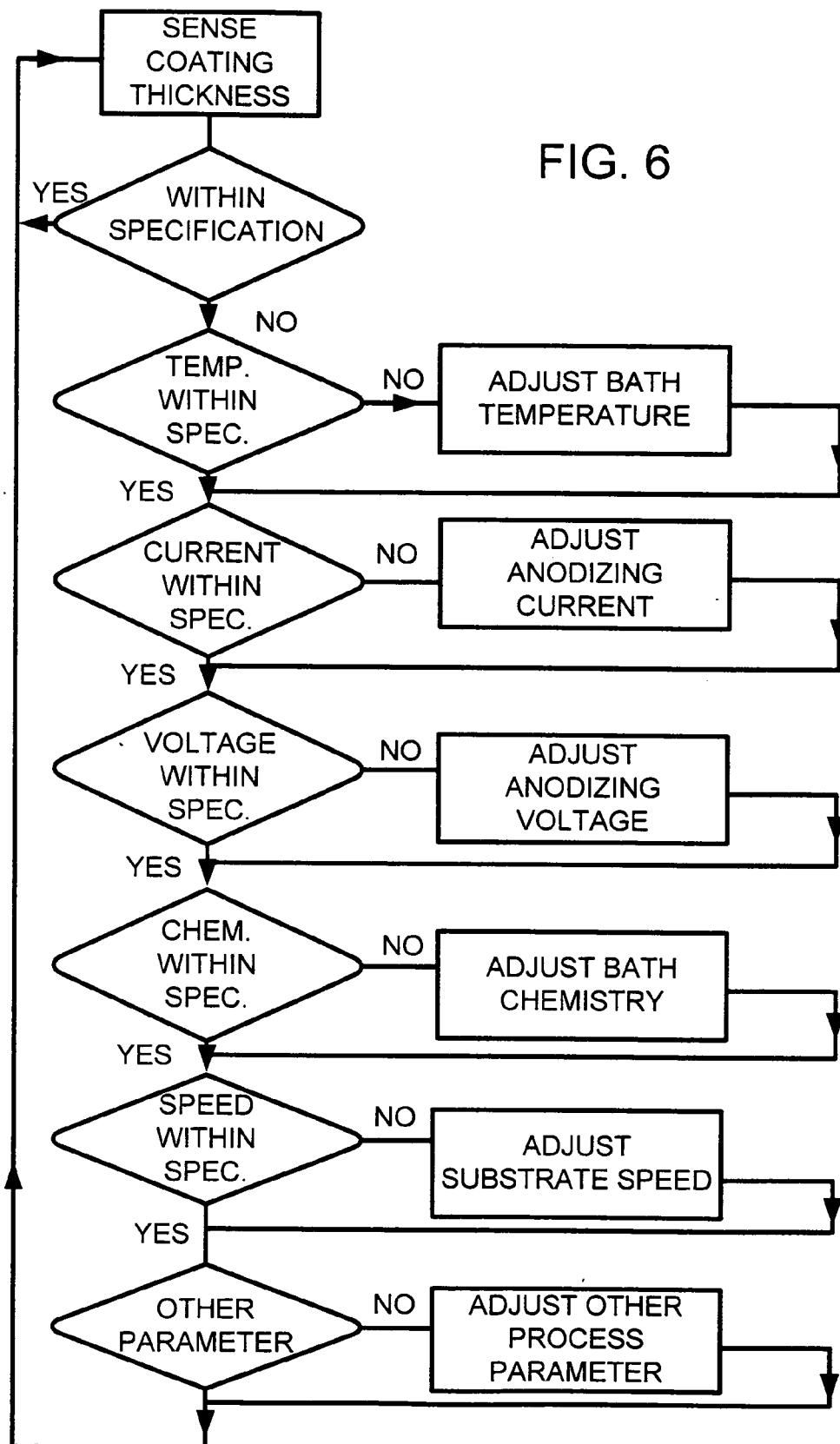

FIG. 6



# Aluminum Alloy 1100 Two layer thickness map (Two layers simultaneously)

User defined limits: Red = Too thick; Green = Within specification; Blue = Too thin

FIGURE 7A

FIGURE 7B

FIGURE 7C

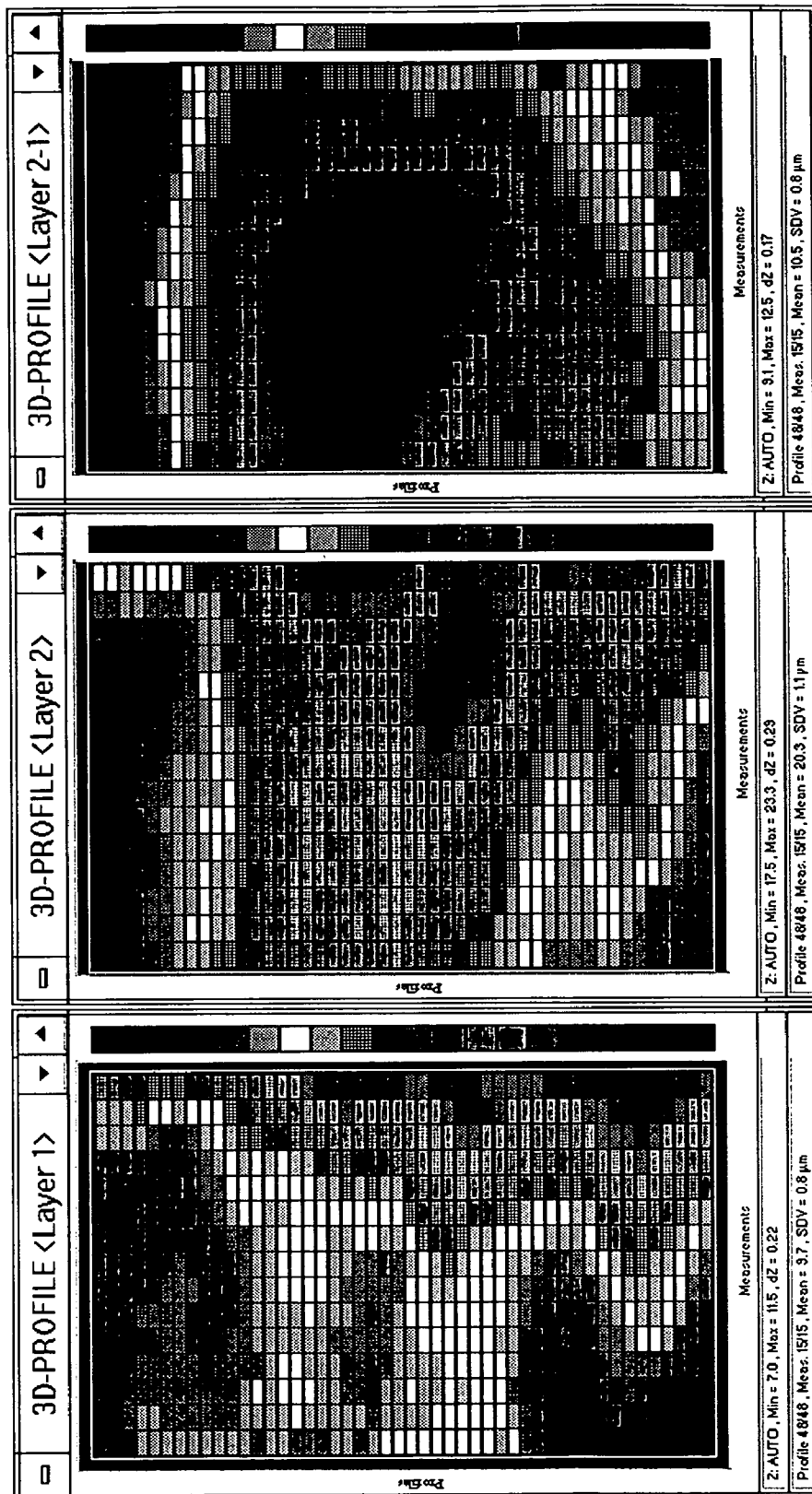

### Comparison of Fixed Measurement, Scanned Measurement, & Measurements Using An SEM For An Aluminum 7075 Alloy

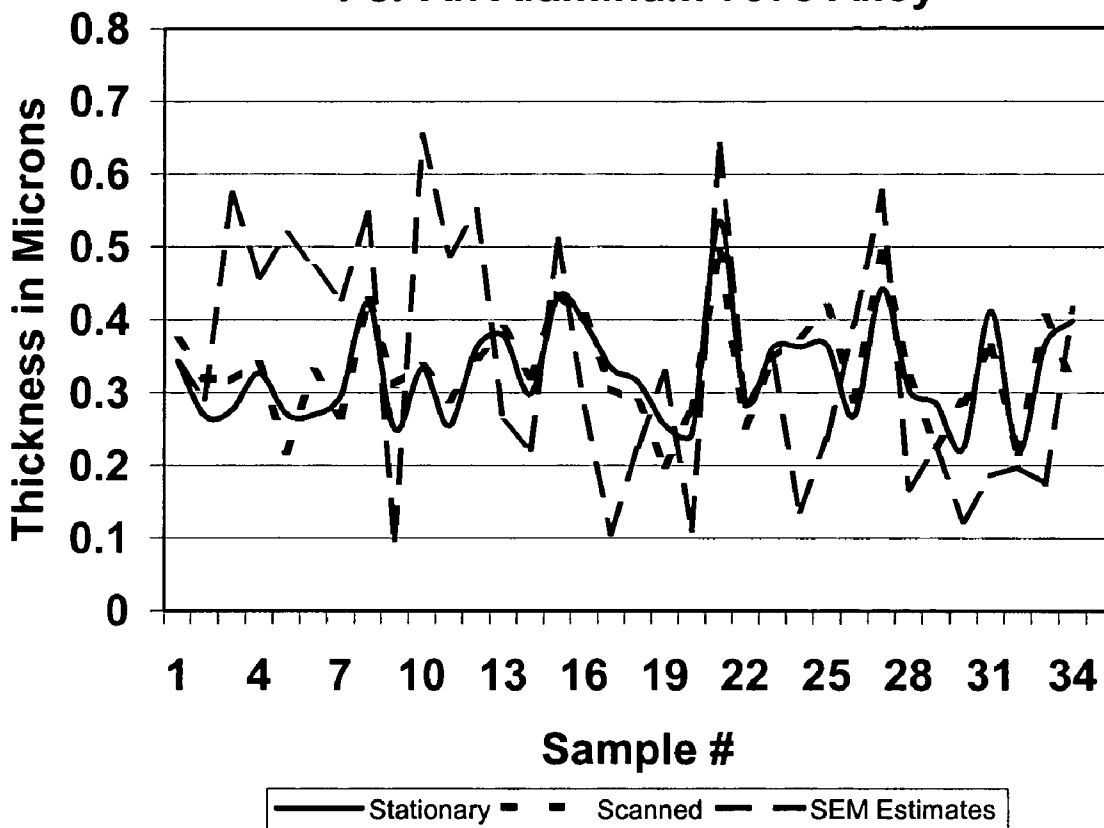

**FIG. 8**

### Comparison Of Fixed Measurement, Scanned Measurement, & Measurements Using A SEM For An Aluminum 2024 Alloy

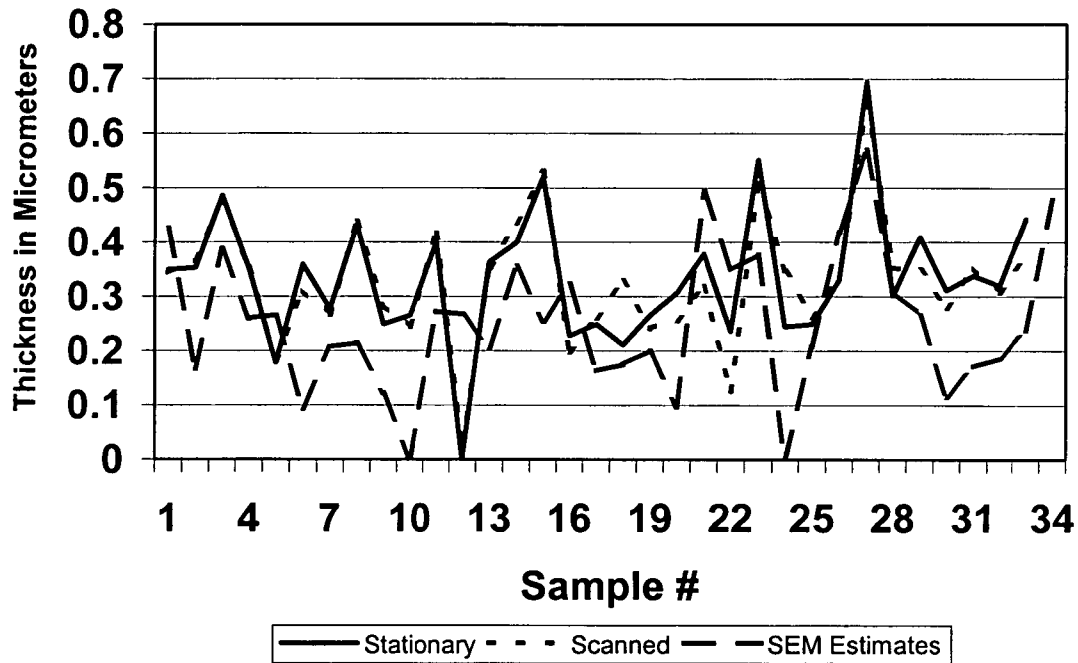

**FIG 9**

## ANODIZING SYSTEM WITH A COATING THICKNESS MONITOR AND AN ANODIZED PRODUCT

### BACKGROUND OF THE INVENTION

#### [0001] (1) Field of the Invention

[0002] The present invention relates generally to anodizing systems including a coating thickness monitor and, more particularly, to a system for regulating an anodized coating thickness on a substrate as it is being formed as well as measuring the coating thickness subsequent to its formation.

#### [0003] (2) Description of the Prior Art

[0004] The coating of metallic substrates such as aluminum and zinc using anodizing is known. Anodizing is done for practical and aesthetic reasons. From a practical perspective, the creation of a coating on the surface of a metallic substrate contributes to an anodized product's wear resistance, corrosion resistance, and oxidation resistance. From an aesthetic perspective, the creation of a coating including a dye for coloration on the surface of a metallic substrate contributes to an anodized product's consumer appeal. In both industrial and aesthetic applications, it is desirable to control the thickness of the anodized coating as well as the consistency over a given surface area.

[0005] Commonly, coating thickness is determined by destructive methods. For example, in a batch anodizing system, control coupons made of the same material as a product to be anodized are included in the anodizing bath. At intermediate times during the anodizing process a control coupon is removed from the bath and destroyed in a manner that permits determining the coating thickness.

[0006] One destructive method includes mounting a control coupon in a Bakelite cross-section, polishing the mounted coupon to a mirror finish and examining the polished cross-section using an optical microscope to determine the coating thickness. A second destructive method includes cutting or breaking a control coupon to expose a cross-section and examining the cross-section using scanning electron microscopy to determine the coating thickness. These destructive methods are cumbersome in production.

[0007] Both destructive methods delay production because of the time taken to remove and prepare control coupons for determining coating thickness. During the delay, the bath is idle. An alternative is to remove the product from the anodizing bath while determining coating thickness and replace it with a second product and corresponding control coupons. In this case, storage area for the product removed from the bath during a coating thickness determination would be required at the production site.

[0008] Although using an anodizing bath alternatively with multiple products provides a solution to production delay, coating flaws can be introduced by bath chemistry changes and surface contagion during storage. That is, the different bath chemistry when the product is reintroduced after the coating thickness determination for further anodizing may create a distinct mismatched interface with the original coating

[0009] During storage, the original coating on the product may also be damaged during removal from and replacement into the anodizing bath. Particulate matter such as dust also

may attach to the surface to introduce further interfacial flaws between the original coating and the further coating.

[0010] The above destructive methods have another serious flaw, namely, that the determined coating thickness is that of a control coupon and not of the product. Thus, the coating thickness of the product is only an estimate and the coating thickness consistency over the entire surface of the product is unknown.

[0011] Thus, there remains a need for a new and improved anodizing system that includes a coating thickness monitor that nondestructively determines the coating thickness on a product, while at the same time, has the ability to control the anodizing system. There also remains a need for a coating thickness monitor that nondestructively determines the coating thickness on an anodized product.

### SUMMARY OF THE INVENTION

[0012] The present invention is directed to an anodizing system for forming an anodized coating on at least a portion of a substrate thereby creating an anodized substrate. The anodizing system includes a bath, a coating thickness monitor, at least one probe, and at least one controller. The substrate is placed into the bath to facilitate the formation of the anodized coating on at least a portion of the substrate, thereby creating the anodized substrate. The coating thickness monitor measures the thickness of at least a portion of the anodized coating formed on the substrate in the bath. The coating thickness monitor includes at least one radiation source directed at at least a portion of the anodized substrate; at least one probe for capturing at least a portion of the radiation reflected and refracted by the anodized coating on the anodized substrate, the captured radiation being at least a portion of the radiation directed the anodized substrate from the radiation source; at least one detector in communication with the at least one probe, the at least one detector capable of processing the captured radiation to allow a determination of at least the thickness of the anodized coating on the substrate; and at least one guide system capable of transmitting the captured radiation from the at least one probe to the at least one detector. The at least one controller is in communication with the coating thickness monitor and the bath.

[0013] In one embodiment, the at least one controller regulates a relative movement of the probe and the anodized substrate. In another embodiment, the at least one controller regulates at least one process parameter of the bath. Preferably, the regulate process parameter includes at least one of bath chemistry, bath temperature, anodizing voltage, anodizing current and anodizing time. In another embodiment, the at least one controller regulates a process endpoint.

[0014] The guide system for the captured radiation may be an optical guide, preferably, an optical fiber, more preferably, a plurality of optical fibers.

[0015] An additional guide system may be added to the coating thickness monitor. This additional guide system is capable of transmitting at least a portion of the radiation from the at least one radiation source to direct at least a portion of the radiation at at least a portion of the anodized substrate. The additional guide system may be an additional optical guide, preferably an optical fiber, more preferably, a plurality of optical fibers.

[0016] Also, a supplementary guide system may be added to the coating thickness monitor. The supplementary guide system is capable of at least one of: (1) transmitting additional captured radiation from the at least one probe to the at least one detector; (2) transmitting at least a portion of the radiation from at least one additional radiation source to direct at least a portion of the additional radiation at at least a portion of the anodized substrate; and (3) transmitting at least a portion of the additional radiation from at least one additional radiation source to direct the at least a portion of the additional radiation at at least a portion of the anodized substrate and transmitting the additional captured radiation from the at least one probe to the at least one detector, the additional captured radiation being at least a portion of the additional radiation directed at the anodized substrate from the at least one additional radiation source. The supplementary guide may be an additional optical guide, preferably an optical fiber, more preferably a plurality of optical fibers.

[0017] The guide system and the supplementary guide system are selected to be capable of transmitting a broad spectral range of captured radiation from the at least one probe to the at least one detector.

[0018] In one embodiment, the at least one radiation source is polychromatic and includes at least one of ultraviolet radiation, visible radiation, and infrared radiation. In another embodiment, the at least one source radiation is monochromatic. An additional radiation source may also be included with the coating thickness monitor. In one embodiment, the additional radiation is polychromatic and includes at least one of ultraviolet radiation, visible radiation, and infrared radiation. In another embodiment, the additional radiation is monochromatic. In a preferred embodiment relating to at least one radiation source and an additional radiation source, a spectral range of the at least one radiation source and a spectral range of the additional radiation source partially overlap. The partial overlap increases at least one of a signal to noise ratio for the captured radiation and a total spectral range of captured radiation. Preferably, one of the at least one radiation source and the additional radiation source is visible radiation and the other of the at least radiation source and the additional radiation source is infrared radiation.

[0019] The at least one probe may further include a collimator that facilitates a depth of field of a sufficient value to measure the anodized coating thickness. In one embodiment, the at least one probe is external to the bath. In an alternative embodiment, the at least one probe is within the bath.

[0020] The at least one detector may include an interferometer. The processing of the captured radiation to determine the coating thickness by the coating thickness monitor includes at least one of using a color, using an interference pattern, using an amount of absorbed radiation, using an intensities ratio of a minimum reflected radiation wavelength and a maximum reflected radiation wavelength, and using a Fast Fourier Transformation (FFT) of the captured radiation. Preferably, the processing of the captured radiation to determine the coating thickness by the coating thickness monitor includes using a Fast Fourier Transformation (FFT) of the captured radiation.

[0021] Accordingly, one aspect of the present invention is to provide an anodizing system for forming an anodized

coating on at least a portion of a substrate thereby creating an anodized substrate. The anodizing system includes a bath and a coating thickness monitor. The substrate is placed into the bath to facilitate the formation of the anodized coating on at least a portion of the substrate thereby creating the anodized substrate. The coating thickness monitor measures the thickness of at least a portion of the anodized coating on the substrate formed in the bath. The coating thickness monitor includes at least one radiation source directed at at least a portion of the anodized substrate, at least one probe for capturing at least a portion of the radiation reflected and refracted by the anodized coating on the anodized substrate, the captured radiation being at least a portion of the radiation directed to the anodized substrate from the radiation source, and at least one detector in communication with the at least one probe, the at least one detector capable of processing the captured radiation to allow a determination of at least the thickness of the anodized coating on the substrate.

[0022] Another aspect of the present invention is to provide a coating thickness monitor for measuring the thickness of at least a portion of an anodized coating on at least a portion of a substrate. The anodizing system has a bath into which the substrate is placed to facilitate the formation of the anodized coating on the substrate thereby creating the anodized substrate. The coating thickness monitor includes at least one radiation source directed at at least a portion of the anodized substrate; at least one probe for capturing at least a portion of the radiation reflected and refracted by the anodized coating on the anodized substrate, the captured radiation being at least a portion of the radiation directed the anodized substrate from the radiation source; at least one detector in communication with the at least one probe, the at least one detector capable of processing the captured radiation to allow a determination of at least the thickness of the anodized coating on the substrate, and a guide system capable of transmitting the captured radiation from the at least one probe to the at least one detector.

[0023] Still another aspect of the present invention is to provide an anodizing system for forming an anodized coating on at least a portion of a substrate thereby creating an anodized substrate. The anodizing system includes a bath, a coating thickness monitor, at least one probe and at least one controller. The substrate is placed into the bath to facilitate the formation of the anodized coating on at least a portion of the substrate thereby creating the anodized substrate. The coating thickness monitor measures the thickness of at least a portion of the anodized coating formed on the substrate in the bath. The coating thickness monitor includes at least one radiation source directed at at least a portion of the anodized substrate, at least one probe for capturing at least a portion of the radiation reflected and refracted by the anodized coating on the anodized substrate, the captured radiation being at least a portion of the radiation directed the anodized substrate from the radiation source, at least one detector in communication with the at least one probe, the at least one detector capable of processing the captured radiation to allow a determination of at least the thickness of the anodized coating on the substrate, and at least one guide system capable of transmitting the captured radiation from the at least one probe to the at least one detector. The at least one controller is in communication with the coating thickness monitor and the bath.

[0024] These and other aspects of the present invention will become apparent to those skilled in the art after a reading of the following description of the preferred embodiments, when considered with the drawings.

#### BRIEF DESCRIPTION OF THE DRAWINGS

[0025] FIG. 1 depicts an anodizing system including a coating thickness monitor according to an aspect of the present invention;

[0026] FIG. 2 depicts an alternative anodizing system including a coating thickness monitor according to an aspect of the present invention;

[0027] FIG. 3 depicts a probe of a coating thickness monitor adjacent to a substrate suitable useable with an anodizing system as depicted in FIGS. 1 and 2 according to an aspect of the present invention;

[0028] FIG. 4 depicts a block diagram of the coating thickness monitor useable with an anodizing system as depicted in FIGS. 1 and 2 according to an aspect of the present invention;

[0029] FIG. 5 depicts a controller block diagram useable with an anodizing system as depicted in FIG. 1 according to an aspect of the present invention;

[0030] FIG. 6 depicts a controller block diagram useable with an anodizing system as depicted in FIG. 2 according to an aspect of the present invention;

[0031] FIG. 7A depicts a topographic thickness profile of a first layer over an area of an anodized aluminum 1100 alloy substrate according to an aspect of the present invention;

[0032] FIG. 7B depicts a topographic thickness profile of a second layer over the same area as shown in FIG. 7A of an anodized aluminum 1100 alloy substrate according to an aspect of the present invention;

[0033] FIG. 7C depicts a composite topographic thickness profile of the first layer of FIG. 7A and the second layer of FIG. 7B of an anodized aluminum 1100 alloy substrate according to an aspect of the present invention;

[0034] FIG. 8 depicts a comparison of coating thickness determine by fixed measurement, scanned measurement, and measurement made using a scanning electron microscope for an anodized aluminum 7075 alloy substrate according to an aspect of the present invention; and

[0035] FIG. 9 depicts a comparison of coating thickness determine by fixed measurement, scanned measurement, & measurement made using a scanning electron microscope for an anodized aluminum 2024 alloy substrate according to an aspect of the present invention.

#### DESCRIPTION OF THE PREFERRED EMBODIMENTS

[0036] In the following description, like reference characters designate like or corresponding parts throughout the several views. Also in the following description, it is to be understood that such terms as "forward," "rearward," "left," "right," "upwardly," "downwardly," and the like are words of convenience and are not to be construed as limiting terms.

[0037] Referring now to the drawings in general and FIG. 1 in particular, it will be understood that the illustrations are

for the purpose of describing a preferred embodiment of the invention and are not intended to limit the invention thereto. As best seen in FIG. 1, an anodizing system 10 includes a bath 16 and a coating thickness monitor 12. A substrate 62 is submersed into the bath 16 for coating. The anodizing system 10 may further include a controller 14.

[0038] The coating thickness monitor 12 includes at least one radiation source 20, a probe 24 for capturing radiation reflected and/or refracted from the substrate 62 and through the coating 72, and a detector 26 that is coupled to the probe 24. The detector 26 deconvolutes the spectrum of the captured reflected and/or refracted radiation to determine the coating thickness.

[0039] In FIG. 1, the probe 24 is shown to be within the bath 16. However, Applicant contemplates that the probe 24 may be outside of bath 16, as shown in FIGS. 2 & 3. In such an arrangement, the substrate 62 may be removed from the bath 16 at intermediate times and probe 24 moved along the substrate 62 surface without contacting the surface to determine the coating thickness over the surface area of the substrate 62. It is advantageous for probe 24 to move over the surface of the substrate 62 without contacting the surface to not be altered or damaged coating 72 during the thickness determination.

[0040] The bath 16 includes an electrode 48, a treatment bath 50, a power source 52, which may be a direct current power source. Also, bath 16 may include a reservoir 54 for storing an electrolyte 53 and a pump 55 for circulating the electrolyte 53. The electrolyte 53 is supplied to the treatment bath 50 through a feed pipe 56 and an electrolyte inlet 57 in the treatment bath 16. A portion of the electrolyte 53 may be returned to the reservoir 54 through an electrolyte outlet 58 and a return pipe 59. Another portion of the electrolyte 53 may be returned to the reservoir 54 through an overflow port 60 and an overflow pipe 61. The electrolyte 53 in the reservoir 54 is controlled by a predetermined temperature and by a means of controller 14.

[0041] When power source 52 is a direct current (DC) power source, the electrode 48 in electrolyte bath 51 is connected to the plus terminal of the DC power source 52. Substrate 62 is connected to the minus terminal of the DC power source 52. When electric current is supplied from the DC power source 52 under these conditions, it flows through the electrode 48 and the electrolyte 53. The electrical current then flows into the substrate 62 through an anodizing film 72. The electric current then flows back to the DC power supply 52. More details concerning baths and anodizing systems are discussed in, for example, U.S. Pat. No. 5,851,373; U.S. Pat. No. 5,693,208; U.S. Pat. No. 4,894,127; U.S. Pat. No. 4,537,664; U.S. Pat. No. 4,478,689; U.S. Pat. No. 4,251,330; U.S. Pat. No. 4,014,758; and U.S. Pat. No. 3,959,091, the entire disclosure of each being incorporated by reference herein.

[0042] Turning now to FIG. 2, there is shown a continuous anodizing process, the view being generally diagrammatic. This anodizing system 10 likewise includes a bath 16 and a coating thickness monitor 12. A probe 24 captures the reflected and/or refracted radiation from a substrate 62, which may include a foil, sheet, or wire product. In this anodizing system 10, substrate 62 is provided on a supply roll (roll depicted on the right of FIG. 2). After anodizing, the substrate 62, including a coating 72, is removed on a

take-up roll (roll depicted on the left of FIG. 2). Prior to anodizing, the surfaces of substrate 62 may be cleaned by immersing the substrate 62 in a detergent (first tank depicted to the left of the supply roll in FIG. 2) to remove foreign materials such as grease and dust that interfere with coating adhesion. A further cleaning of the substrate 62 may include a pickling operation (second tank depicted to the left of the supply roll in FIG. 2) the process of removing scale or other surface compounds by immersion in a suitable aggressive liquid; sometimes electrochemically assisted to clean the surface) followed by an acid removal step (third tank depicted to the left of the supply roll in FIG. 2) that may involve immersing the substrate 62 in deionized water. The continuous anodizing of the substrate 62 may then follow.

[0043] After anodizing, a probe 24 is used for measuring the thickness of the coating 72. In an aspect of the present invention, a probe 24 remains stationary as an anodized substrate 62 moves by, thereby measuring a thickness along a length of the product. In another aspect of the present invention, a probe 24 also moves substantially perpendicular to the direction of the movement of an anodized substrate 62 thereby measuring a thickness along an area of the substrate. In this manner, a coating thickness distribution over the surface of a product such as a sheet, coil or foil may be determined. As best seen in FIG. 3, a robotic arm may be used to move a probe 24 across a substrate 62 having a coating 72 to determine the coating thickness at a select point, a select region or even over the entire surface of a product. More details concerning motion control and robotics are discussed in, for example, U.S. Pat. No. 5,872,892; U.S. Pat. No. 4,979,093; U.S. Pat. No. 4,835,710; U.S. Pat. No. 4,417,845; U.S. Pat. No. 4,352,620; and U.S. Pat. No. 4,068,156, the entire disclosure of each being incorporated by reference herein.

[0044] As best seen in FIGS. 1 and 2, a coating thickness monitor 12 includes at least one radiation source 20, a probe 24 for capturing the reflected and/or refracted radiation, and a detector 26 for measuring or deconvoluting the spectrum of the reflected and/or refracted radiation.

[0045] A radiation source 20 may be polychromatic, for example, ultraviolet (UV), visible, infrared (IR), or monochromatic. A radiation source 20 that is polychromatic may be a subset of any of UV (having wavelengths in the range of about 4 to about 400 nanometers), visible (having radiation wavelengths to which the organs of sight react, ranging from about 400 to about 700 nanometers), and IR (having wavelengths between 750 nanometers and 1 millimeter). Examples of such subsets include vacuum ultraviolet radiation (UV radiation having wavelengths less than about 200 nanometers; so-called because at shorter wavelengths the radiation is strongly absorbed by most gases), far-ultraviolet radiation (the short-wavelength region of the UV range: about 50 to about 200 nanometers), near-ultraviolet radiation (ultraviolet radiation having wavelengths in the range of about 300 to 400 nanometers), far-infrared radiation (long-wavelength region of the infrared range: about 50 to about 1000 micrometers) and near-infrared radiation (radiation having wavelengths in the range of about 0.75 to about 2.5 micrometers). Alternatively, a radiation source 20 may be monochromatic.

[0046] In an embodiment, a coating thickness monitor 12 includes an additional radiation source 28. The radiation

source 20 and additional radiation source 28 may be any one of polychromatic and monochromatic and are selected to compliment each other to improve, for example, the intensity and breadth of reflected radiation available for determining the thickness of a coating 72 on a substrate 62. Typically, a single radiation source has an intensity that is greatest in a central range but decreasing on either end. By complimenting this with an additional source of radiation, there can be an overlap of the decreasing intensities to remove them. In this way, several advantages may be realized. For example, there may be an increase of signal to noise ratio with respect to the reflected radiation. Also, there may be an increase in the range of reflected radiation that can be captured. In this way, the other aspects of a coating's properties may be determined.

[0047] As seen in FIGS. 1 and 2, the probe 24, for capturing the reflected and/or refracted radiation, includes a guide for delivering the radiation back to the detector 26. As shown in FIG. 3, the probe 24, for capturing and directing the reflected and/or refracted radiation back to the detector 26, may include a collimator 34. The collimator 34 may be used to direct the captured reflected radiation into the coupler that directs the radiation to the detector 26. As mentioned earlier, the probe 24 may either be external to the bath 16 or within the bath.

[0048] The detector 26 is the type that demodulates the reflected spectrum once it is received. Examples of equipment that might be used with this are included in, for example, U.S. Pat. No. 6,052,191; U.S. Pat. No. 5,999,262; U.S. Pat. No. 5,289,266; U.S. Pat. No. 4,748,329; U.S. Pat. No. 4,756,619; U.S. Pat. No. 4,802,763; U.S. Pat. No. 4,872,755; and U.S. Pat. No. 4,919,535, the entire disclosure of each being incorporated by reference herein. Part of determining the coating thickness is through demodulating the reflected spectrum. Various techniques are known for measuring this including color interference method, absorption method, ratio of the intensity of the maximum wavelength to the intensity of the minimum wavelength and the fast Fourier transform (FFT) method (e.g., the processing of a signal generated by waves striking a detector, whereby the signal is transformed into a digital time series for spectrum analysis). More details concerning single and multiple coating thickness determination are discussed in, for example, U.S. Pat. No. 6,128,081; U.S. Pat. No. 6,052,191; U.S. Pat. No. 5,452,953; U.S. Pat. No. 5,365,340; U.S. Pat. No. 5,337,150; U.S. Pat. No. 5,291,269; U.S. Pat. No. 5,042,949; U.S. Pat. No. 4,984,894; U.S. Pat. No. 4,645,349; U.S. Pat. No. 4,555,767; and U.S. Pat. No. 4,014,758, the entire disclosure of each being incorporated by reference herein.

[0049] In an embodiment, a coating thickness detector 26 includes a guide system 30. The guide system 30 acts as a coupler to direct the reflected radiation from the probe 24 to the detector 26. The guide system 30 may also act to provide the source radiation to the surface of substrate 62 through the probe 24. Alternatively, a radiation source may be integral to probe 24 to provide the source radiation to capture the reflected radiation from the substrate 62, having a coating 72.

[0050] In a preferred embodiment, guide system 30 is a fiber optic guide that includes a plurality of fibers arranged in a manner to capture the radiation optimally, having a composition that transmits the reflected radiation without

attenuation. The guide system **30** may include multiple components. In a more preferred embodiment, the guide system **30** is coupled with the radiation source **20** to direct radiation to the surface of the substrate **62**, as well as being coupled to the detector **26** to direct the reflected and/or refracted radiation to the detector for analysis. Guide system **30** may include multiple sets of fibers when the coating thickness monitor includes multiple radiation sources and multiple detectors. The configuration and composition of optical fiber bundles are selected to optimally transmit the radiation interest.

**[0051]** As seen in **FIGS. 1 and 2**, the anodizing system **10** may include a controller **14** that may include, for example, a computer **40**. The anodizing system **10** may operate without the computer **40** or an intermediate box to communicate with the controller **14**.

**[0052]** Referring back to **FIG. 1**, and the controller system **14**, the in situ and real time measurement of the coating thickness development by having the probe **24** within the bath **16** may be beneficial. In one aspect of the present invention, the benefits realized by this are the regulation of the anodizing process by controlling the process parameters, for example, the bath chemistry which can be done by controlling pump **55** to bring additional electrolyte to the bath **16** from the reservoir **54**. Also, the anodizing voltage provided by power supply **52** can be adjusted during the process to give the desired coating **72**; likewise, the anodizing current, the bath temperature, as well as the anodizing time, may be controlled. More details concerning controllers that may be used in anodizing system **10** are discussed in, for example, U.S. Pat. No. 5,980,078; U.S. Pat. No. 5,726,912; U.S. Pat. No. 5,689,415; U.S. Pat. No. 5,579,218; U.S. Pat. No. 5,351,200; U.S. Pat. No. 4,916,600; U.S. Pat. No. 4,646,223; U.S. Pat. No. 4,344,127; and U.S. Pat. No. 4,396,976, the entire disclosure of each being incorporated by reference herein.

**[0053]** In this regard, with reference to **FIG. 1**, a controller **14** in combination with the coating thickness monitor **12** may be used as an endpoint determiner in a batch anodizing system. During anodizing, the process parameters may be controlled while allowing an operator to know, in real time, the thickness of the coating **72**. At a time that the coating **72** grows to a desired thickness on the substrate **62**, the process shuts down. Clearly, this ability to know the coating thickness as it grows is advantageous over any method where substrate **62** is removed from the bath **16**, its coating thickness determined and then replaced into the bath.

**[0054]** **FIG. 5** depicts a controller block diagram useable with an anodizing system as depicted in **FIG. 1**. Although the tasks of **FIG. 5** are shown as being performed in a serial manner, Applicant contemplates that the tasks may be performed in parallel and any combination of serial and parallel that accomplishes the purpose, intent and/or function of the present invention. Again referring to **FIG. 5**, a probe is used to determine the coating thickness at any instant of time. Subsequently, a coating rate may be calculated. Then it is determined if the coating thickness has attained the desired value (e.g., whether the thickness is within the desired specification). When the desired coating thickness value has been attained, the coating process is stopped; otherwise, it is

determined if the coating rate is at the desired value (e.g., whether the coating rate is within the desired specification). When a coating rate is not the desired coating rate, the value of other process parameters is measured and compared to a desired value for each (e.g., whether a process parameter is within a desired specification). If any process parameter, such as, bath temperature, anodizing current, anodizing voltage, bath chemistry, . . . etc., is not at its desired value, the process parameter is adjusted, then the query, compare, and adjust cycle is rerun until the desired coating thickness is attained.

**[0055]** A benefit of the present invention is the ability to produce an anodized substrate having a better quality and consistency from batch-to-batch, both linear and areal, over the length and surface better than an anodized substrate made without a coating thickness monitor of the present invention, and preferably, communicating with a controller. Table 1 includes a comparison of the quality (e.g., conformity to design specifications), consistency (e.g., the uniformity of a manufactured anodized substrate from batch-to-batch), and quality x consistency for a batch anodizing system of the present invention and the prior art. Although an anodized substrate of the prior art may be satisfactory with respect to both quality and consistency, an anodized substrate according to the present invention possesses better quality and excellent consistency.

**[0056]** As seen in **FIG. 2**, the interface of the coating thickness monitor **12** and the controller **14** in continuous coating operation may provide numerous advantages. In this system, the real time coating thickness determination may be fed back to control the processing parameters such as bath chemistry, voltage, current and temperature. Likewise, the take up speed may be controlled. In this way, a substrate **62** having an anodized coating that has a more consistent coating thickness per unit length or unit area may be manufactured. That is, by monitoring the coating in real time and adjusting all the process parameters, a more uniform coating can be realized.

**[0057]** **FIG. 6** depicts a controller block diagram useable with an anodizing system, as depicted in **FIG. 2**. Although the tasks of **FIG. 6** are shown as being performed in a serial manner, Applicant contemplates that the tasks may be performed in parallel and any combination of serial and parallel that accomplishes the purpose, intent and/or function of the present invention. Again referring to **FIG. 6**, a probe is used to determine the coating thickness at any instant of time. Subsequently, it is determined if the coating thickness has attained the desired value (e.g., whether the thickness is within the desired specification). When the desired coating thickness value has been attained, the coating process continues; otherwise, it is determined if the value of other process parameters is measured and compared to the desired value for each (e.g., whether a process parameter is within a desired specification). If any process parameters, such as, bath temperature, anodizing current, anodizing voltage, bath chemistry, roll speed, . . . etc., is not at a desired value, the process parameter is adjusted. Then the query, compare, and adjust cycle is rerun until the desired coating thickness is attained.

TABLE I

Comparison Of Anodized Substrate Of The Prior Art And The Present Invention Made By Batch And Continuous Processes			
	Quality*	Consistency*	Quality x Consistency
Prior Art Batch	3	3	9
Invention Batch	4	5	20
Prior Art Continuous	3	3	9
Invention Continuous	5	5	25

\*Quality: 1 = poor, 2 = less than satisfactory, 3 = satisfactory, 4 = more than satisfactory, and 5 = excellent

\*Consistency: 1 = poor, 2 = less than satisfactory, 3 = satisfactory, 4 = more than satisfactory, and 5 = excellent

**[0058]** A benefit of the present invention in regard to a continuous anodizing system is the ability to produce an anodized substrate having a better quality and consistency from location to location, both linear and areal, over the length and better than an anodized substrate made without a coating thickness monitor of the present invention, and preferably, communicating with a controller. A further benefit of the present invention is the ability to produce an anodized substrate having a better quality and consistency from batch-to-batch, both linear and areal, over the length and surface better than an anodized substrate made without a coating thickness monitor of the present invention, and preferably, communicating with a controller. Table 1 includes a comparison of the quality (e.g., conformity to design specifications), consistency (e.g., the uniformity of a manufactured anodized substrate from location to location and/or batch-to-batch), and quality x consistency for a continuous anodizing system of the present invention and the prior art. Although an anodized substrate of the prior art may be satisfactory, with respect to both quality and consistency, an anodized substrate according to the present invention possesses excellent quality and excellent consistency.

**[0059]** In operation, an anodizing system **10** having a coating thickness monitor **12** provides a means for controlling, validating and documenting process quality. Also, these benefits may be realized economically while improving the overall coating. The anodizing system **10** eliminates the subjectivity in process coating of metal substrates and, preferably, aluminum and aluminum alloys. A coating thickness monitor may be used to eliminate defective coated products from a manufacturing stream. In this way, commercial benefits such as reduced scrap, increased throughput, reduced labor costs, and reduced insurance premiums for product liability may be realized.

**[0060]** Protective coatings are used to prevent oxidation and corrosion of the aluminum and its alloys in numerous applications, such as in the aircraft industry. In many applications, after anodizing, additional barrier coatings may be added to promote adhesion of additional coatings, typically of an organic nature, such as epoxies, resins, composite coating components and top coats (e.g., paint and decals).

**[0061]** In an anodizing system **10**, an aluminum substrate is stripped of surface contaminants such as oxidation products, oils (including fingerprints from handling) and waxes.

A washing of the surface of the aluminum substrate in a detergent removes oils and waxes. A pickling operation using a chemical etchant removes oxidation products. Cleaning a substrate surface in this way allows an anodizing current to be evenly distributed across the surface of a product to form a uniform coating thickness (e.g., reduce thickness variation). Also, a low electrical resistance exists at the start of the anodizing operation. Anodizing of aluminum is started immediately following substrates washing and pickling to prevent the formation of any parasitic oxidation products. During anodizing, aluminum oxide crystals grow on the surface as current passes through the surface. Following anodizing, further coatings, as discussed above, may be applied to the substrate.

**[0062]** The thickness of an anodized coating and further coating is measured using the coating thickness monitor **12** of the present invention, that in a preferred embodiment operates using interferometry that is independent of substrate thickness. In this way, coating thickness monitor **12** is non-contact, non-destructive, fast, robust and reliable. Also, coating thickness monitor **12** may facilitate simultaneous thickness measurement of an anodized coating and further coating. The use of a guide(s) based on fiber optic technology provides intrinsic isolation of the coating thickness monitor **12** from the process. Also, in situ measurement inside the anodized bath or at strategic inspection points may be simplified.

**[0063]** In a test of the coating thickness monitor **12** of the present invention, the radiation source was coherent white light provided to a coated substrate by a multiple guide optical coupler composed of a plurality of optical fibers. A first guide illuminated the coated substrate surface and a second guide captured and transmitted the reflected light to a detector. One end of the guide system combines the two guides and is coupled to the coated substrate by collating lenses. The opposite end of the guide system diverges to the radiation source of the detector. The composite reflection is transmitted to the detector, which on this embodiment is a spectrometer. The interference within the composite reflection is superimposed onto the reflection signal. Fast Fourier Transformation (FFT) analysis is used to determine the thickness. The parametric set-up allows the coating thickness monitor **12** to be configured to various coating types.

**[0064]** Equipment used in a coating thickness monitor according to the present invention include a spectrometer (Model DSPec/1024/6 having a DSP based spectrometer with an about 1024 element detector available from Analytical Technologies, L.L.C., Morganton N.C.); a radiation source (Model HALXE 50 having a composite halogen/Xenon spectral lamp, with shutter available from Analytical Technologies, L.L.C., Morganton N.C.); a guide system including a plurality of optical fibers (Model 6/1/SMA/FS made from fused silica with 6 detectors around 1 illuminator in SMA terminal, available from Analytical Technologies, L.L.C., Morganton N.C.); and a probe (Model 50/5/SMA including a tube mounted lens with an about 50 mm focal distance, an about 5mm spot size, SMA terminal, available from Analytical Technologies, L.L.C., Morganton N.C.).

**[0065]** This equipment was interfaced with a personal computer (PC) running a program entitled FTM Pro VIS software available from Dipl.-Ing. (FH) Thomas Fuchs, Ingenieurbüro für Angewandte Spektrometrie, Roentgenstr. 33-D-73431 Aalen-Germany.

[0066] The interference of two light rays may be described with the following simplified formula:

$$I(l)=A+B*\cos [2p*Dr/l+Dd] \text{ where:}$$

[0067]  $I(l)$  is an interference intensity for wavelength  $l$ ;

[0068]  $A$  contains the intensity of the two light rays;

[0069]  $B$  is an amplitude of the cosine function;

[0070]  $l$  is a wavelength;

[0071]  $Dr$  is an optical path difference (thickness); and

[0072]  $Dd$  is a phase shift of the two light rays.

[0073] The optical path difference “ $Dr$ ” itself is the product of the required geometric thickness “ $d$ ” and the refractive index “ $n$ ”:  $Dr=2 n(l)*d$ . Generally, the refractive index “ $n$ ” is a function of the wavelength “ $l$ ”, which is described as “dispersion” (see below) and in the present case was assumed to be about 1.4789 for alumina.

[0074] In the FTM Pro VIS software, the required geometric thickness “ $d$ ” is calculated by the determination of the interference function shown above (the expression “ $Dr/l$ ” corresponds to a frequency function). This frequency was determined with the help of a “Fast Fourier Transformation” (in shortened form: FFT). In the reciprocal representation of the interference spectrum, the peak position of the Fourier-transformed interference (the Fourier-spectrum, or short: FFT-spectrum), with known dispersion “ $n(l)$ ”, directly supplies the film thickness. The FTM Pro VIS software may take into account the dispersion by using a polynomial formula, following the dispersion formula according to Cauchy (dispersion correction):

$$n(l)=n+B/l^2+C/(l^{2*12}),$$

where:

[0075]  $n(l)$  is the dispersion of a wavelength  $l$ ;

[0076]  $n$  is a polynomial constant;

[0077]  $B$  and  $C$  are polynomial factors; and

[0078]  $l$  is a wavelength.

[0079] An aluminum 1100 alloy substrate having an anodized coating and a polymer coating was tested using a coating thickness monitor 10 according to the present invention. Scanning electron microscopy (SEM) measurements (viewing area of about 1.5 square micrometers) of coated sample cross sections were used to confirm parametric (set-up) conditions of the coating thickness monitor 10 and illustrate surface topography. An area of interest on an aluminum 1100 alloy substrate was adjustable. An about 3.75 millimeter diameter light spot size produced an about 5.89 square millimeter analyzed area. The measurement speed was set at about 500 measurements per second. The capability of multi-layer analysis was verified by the simultaneous coating thickness measurement of an anodized coating and polymer coating. The coating thickness measurements were independent of substrate thickness and eliminated any need for destructive, time consuming cross-sectioning.

[0080] Also, it was seen that larger surface areas may be accurately measured. FIG. 7A depicts a topographic thickness profile of a first layer over an area of an anodized

aluminum 1100 alloy substrate. FIG. 7B depicts a topographic thickness profile of a second layer over the same area, as shown in FIG. 7A, of the anodized aluminum 1100 alloy substrate. FIG. 7C depicts a composite topographic thickness profile of the first layer of FIG. 7A and the second layer of FIG. 7B of the anodized aluminum 1100 alloy substrate. This data may be used for determining the quality and consistency of the anodized substrate of the present invention. A user of the present invention may set ranges for a first layer and/or a second layer. An algorithm may perform the task of developing a topographic result, and the result may be color-coated for too thick, within specification, and too thin of a coating.

[0081] Coating thickness measurements were also made on an aluminum 7075 alloy substrate having an anodized coating and an aluminum 7075 alloy substrate having an anodized coating using a coating thickness monitor 10, according to the present invention. As with the aluminum 1100 alloy substrate, scanning electron microscopy (SEM) measurements were made. Two measurement modes, namely, fixed and scanning, were compared to measurements using an SEM. The measurement interval was about 1 mm for the total scan area. The wavelength range for the FTM Pro VIS software was specified from about 450 to about 950 nanometers. About 500 measurements per scan over an about 1 mm scan area were made. FIG. 8 depicts a comparison of coating thickness determined by fixed measurement, scanned measurement, and measurements made using a scanning electron microscope for an anodized aluminum 7075 alloy substrate according to an aspect of the present invention. FIG. 9 depicts a comparison of coating thickness determined by fixed measurement, scanned measurement, and measurements made using a scanning electron microscope for an anodized aluminum 2024 alloy substrate, according to an aspect of the present invention. These results show that the measurement of the coating thickness may be performed by either fixed measurements or scanned measurements. Both measurement techniques correlate well with the measurements made using a SEM while being nondestructive and non-contact.

[0082] Certain modifications and improvements will occur to those skilled in the art upon a reading of the foregoing description. By way of example, a real time process to control specified layer thickness for anodizing and a further coating of a substrate may be achieved based upon using an optical interference measurement technique employing monochromatic or polychromatic illumination or detection and an evaluation algorithm for determining thickness based upon FFT. Likewise, a statistical surface evaluation technique for layer thickness profiles using one or more axis of movement over any area of interest, either manually or automated multi-axis positioning system, may be suitable for use in a dip tank, or in an inspection booth. Further, the measurement on multiple surfaces (front, rear, or side) of flat piece goods may be achieved. A measurement mode on curved surfaces of irregular shape could also be achieved.

[0083] Also, appropriate measuring points on a parts rack could be achieved. This may be affected by aligning the optical sensors to achieve correct optical throughput and by positioning the measuring probe in various points on a sample part racks. Further, positioning the measuring probe on front, rear, or side of a part may be beneficial. Moreover, finding a statistical variation thickness would be helpful in

process control and product quality and consistency. This might be affected by determining average thickness over a desired area of interest; determining the statistical variation in thickness over a desired area of interest; or determining thresholds of acceptability.

[0084] It should be understood that all such modifications and improvements have been deleted herein for the sake of conciseness and readability but are properly within the scope of the following claims.

1-70. (canceled)

71. A method for forming an anodized coating on at least a portion of a substrate thereby creating an anodized substrate, said method including:

- (a) using an anodizing system having a bath;
- (b) placing the substrate into the bath to facilitate the formation of the anodized coating on at least a portion of the substrate thereby creating the anodized substrate; and
- (c) measuring the anodized coating with a coating thickness monitor to determine the thickness of at least a portion of the anodized coating on the substrate formed in said bath, said measuring including:
  - (i) directing at least one radiation source at at least a portion of the anodized substrate;
  - (ii) capturing with at least one probe at least a portion of the radiation reflected and refracted by the anodized coating on the anodized substrate, the captured radiation being at least a portion of the radiation directed the anodized substrate from said radiation source; and
  - (iii) transmitting to at least one detector from said at least one probe said captured radiation, said at least one detector capable of processing the captured radiation to allow a determination of at least the thickness of the anodized coating on the substrate.

72. A method for measuring using a coating thickness monitor the thickness of at least a portion of an anodized coating on at least a portion of a substrate formed in an anodizing system having a bath into which the substrate is placed to facilitate the formation of the anodized coating on the substrate thereby creating the anodized substrate, said method including:

- (a) providing coating thickness monitor;
- (b) directing at least one radiation source at at least a portion of the anodized substrate;

(c) capturing using at least one probe at least a portion of the radiation reflected and refracted by the anodized coating on the anodized substrate, the captured radiation being at least a portion of the radiation directed the anodized substrate from said radiation source;

(d) transmitting the captured radiation using a guide system from said at least one probe to said at least one detector; and

(e) processing the captured radiation to allow a determination of at least the thickness of the anodized coating on the substrate.

73. A method for forming an anodized coating using an anodizing system on at least a portion of a substrate thereby creating an anodized substrate, said method including:

- (a) providing anodizing system;
- (b) placing the substrate into a bath to facilitate the formation of the anodized coating on at least a portion of the substrate thereby creating the anodized substrate;
- (c) measuring using a coating thickness monitor a thickness of at least a portion of the anodized coating on the substrate formed in said bath, said measuring using the coating thickness monitor including:
  - (i) directing at least one radiation source at at least a portion of the anodized substrate;
  - (ii) capturing using at least one probe at least a portion of the radiation reflected and refracted by the anodized coating on the anodized substrate, the captured radiation being at least a portion of the radiation directed the anodized substrate from said radiation source;
  - (iii) transmitting using at least one guide system the captured radiation from said at least one probe to at least one detector; and
  - (iv) processing the captured radiation to allow a determination of at least the thickness of the anodized coating on the substrate; and

(d) communicating the determined coating thickness with at least one controller.

74-77. (canceled)

\* \* \* \* \*